

Ball Python Lavender Albino DNA Test

Version: 2.0

Release: May 2023
©2023 by miniPCR Dx™

CONTENTS

| | |
|--|----|
| CONTENTS..... | 1 |
| OVERVIEW | 2 |
| TYPICAL RESULT | 2 |
| PROTOCOL AT GLANCE..... | 3 |
| KIT COMPONENTS | 4 |
| SUPPLIED IN KIT | 4 |
| SUPPLIED BY USER..... | 5 |
| BEFORE YOU START | 8 |
| LABORATORY GUIDELINES..... | 8 |
| CONTROLS..... | 9 |
| TUBE TYPES..... | 10 |
| MICROPIPETTING | 11 |
| LIQUID HANDLING | 12 |
| PROGRAM THE miniPCR® OR OTHER THERMAL CYCLER | 13 |
| SHED COLLECTION | 14 |
| SCIENTIFIC BASIS OF THE ASSAY..... | 15 |
| PROTOCOL..... | 17 |
| STEP 1. SETUP (10 MIN) | 17 |
| STEP 2. LYSIS (20 MIN)..... | 20 |
| STEP 3. PCR (95 MIN) | 22 |
| STEP 4. DNA GEL ELECTROPHORESIS AND VISUALIZATION (45 MIN) | 24 |
| EXPECTED RESULTS | 28 |
| EXAMPLE RESULTS | 28 |

Ball Python Lavender Albino DNA Test

OVERVIEW

gelPCR™ tests use PCR and DNA gel electrophoresis for genotyping purposes. The Ball Python Lavender Albino DNA Test is a gelPCR™ test to detect a deletion in the OCA2 gene responsible for the Lavender Albino color in ball pythons (*Python regius*).

TYPICAL RESULT

The allele associated with the Lavender Albino phenotype will produce a ~350 bp band, while the wild-type (WT) allele will yield a ~430 bp band.

- Homozygous wild-type snakes will yield a single ~430 bp band
- Homozygous Lavender Albino snakes will produce a single ~350 bp band
- Heterozygous Lavender Albino snakes will produce two bands (~350 and ~430 bp)

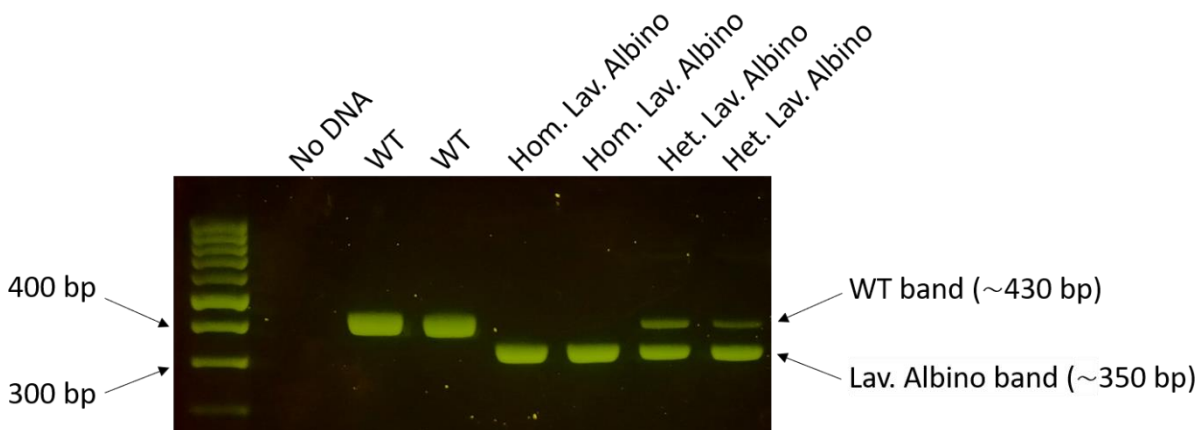

Ball Python Lavender Albino DNA Test

PROTOCOL AT GLANCE

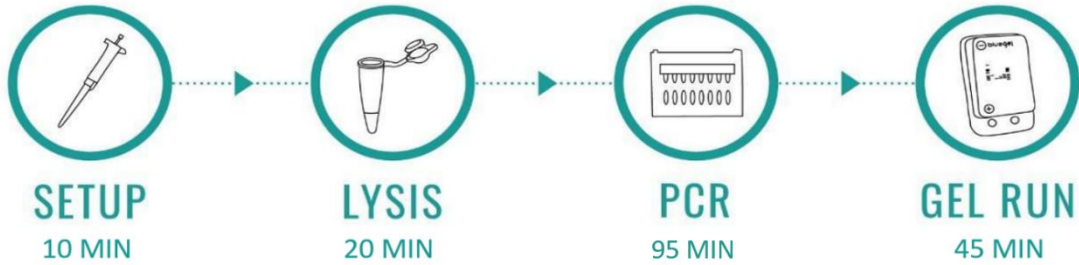

**For processing
8 samples**



**Total
time**



**Hands-on
time**

KIT COMPONENTS

The Ball Python Lavender Albino DNA Test has material for 38 tests, including samples and controls.

SUPPLIED IN KIT

| Reagents and Supplies | Quantity | Storage |
|---|-----------|------------|
| 5X HOT Multiplex PCR Master Mix | 1 tube | Freezer |
| 1.2X Lav. Albino Primers | 1 tube | Freezer |
| gelPCR™ Control 1 | 1 tube | Freezer |
| DEB™ Extraction Buffer | 2 tubes | Freezer |
| 100 bp DNA ladder, Load Ready™, 20 lanes | 1 tube | Freezer |
| Strips of 8 PCR tubes | 10 strips | Room temp. |

SUPPLIED BY USER

Available at dx.minipcr.com

Equipment

These items will be a one-time purchase.

If you're starting your lab, we recommend the [gelPCR™ Bundles](#) (QP-2510-30 and QP-2510-40), which includes the equipment and consumables listed below, except for the optional centrifuge.

Alternatively, here is the list of all the recommended equipment. All are available at <https://dx.minipcr.com>.

| Item | Quantity | Recommended product | Cat. Number |
|--|----------|---|-------------|
| Thermal cycler | 1 | miniPCR® mini8X thermal cycler | QP-1000-08 |
| | | miniPCR® mini16X thermal cycler | QP-1016-16 |
| Gel electrophoresis and visualization system | 1 | blueGel™ electrophoresis with built-in transilluminator | QP-1500-01 |
| | | GELATO™ electrophoresis and visualization system | QP-1600-01 |
| Micropipettes • 1-10 µl • 2-20 µl • 20-200 µl • 100-1000 µl | 1 each | 1-10 µl H-style | QP-1001-05 |
| | | 2-20 µl H-style | QP-1001-01 |
| | | 20-200 µl H-style | QP-1001-03 |
| | | 100-1000 µl H-style | QP-1002-02 |
| Microcentrifuge tube rack | 1 | Microcentrifuge tube rack, 60-well | CM-1003-10 |
| PCR tube rack | 2 | miniRack | CM-1003-04 |
| Microcentrifuge (optional)¹ | 1 | Gyro™ Microcentrifuge, fixed speed | QP-1800-01 |

¹ Microcentrifuging tubes will guarantee that the liquid collects at the bottom of the tubes, reducing contamination risk. Alternatively, flick tubes (see the "Liquid handling" section).

Ball Python Lavender Albino DNA Test

Consumables

DNA gel electrophoresis reagents and plastic consumables will need to be refilled.

We recommend the Learning Lab Companion Kit (KT-1510-01) to refill DNA gel electrophoresis reagents and microcentrifuge tubes. One Learning Lab Companion Kit will provide enough material for running 38 reactions of the Ball Python Lavender Albino DNA Test.

Here is the complete list of all the necessary consumables.

| Item | Quantity | Recommended product | Cat. Number |
|---|--|---|-------------|
| Micropipette filter tips | 2 boxes each | 1-10 µl | 4AA75 |
| | | 2-20 µl | 4AA76 |
| | | 20-200 µl | 4AA77 |
| | | 100-1000 µl | 4AA78 |
| TBE Buffer | Enough for making 600 ml – recommended if using blueGel™ | TBE electrophoresis buffer, powder makes 600 ml | RG-1502-04 |
| | Enough for making 3 L - recommended if using GELATO™ | TBE electrophoresis buffer, powder makes 3 L | RG-1502-05 |
| DNA gel electrophoresis reagents | Enough for preparing 8 small gels or 4 large gels. | SeeGreen™ All-in-One Agarose Tabs™, 8pcs | RG-1500-21 |
| Microcentrifuge tubes | >10 tubes | Microtubes 1.5 ml | 6AA02 |

Ball Python Lavender Albino DNA Test

Other laboratory supplies

- Disposable laboratory gloves
- Bottle and DI water for preparing TBE buffer
- Container (e.g. flask or beaker) for preparing the gels
- Protective eyewear
- Lab coat
- Bottle or sprayer with 5% bleach (1 part bleach + 19 parts water)
- Permanent marker
- Disposable tweezers
- Disposable toothpicks
- Container with lid to dispose of tubes and tips
- Parchment paper or similar to place the samples on
- Zip lock bags for collecting samples

BEFORE YOU START

LABORATORY GUIDELINES

PCR is an extremely sensitive technology that can detect minute amounts of DNA. Always follow the practices outlined below to minimize the risk of contamination.

- Set up your lab in an area that is removed from possible sources of snake DNA (e.g., away from the husbandry area).
- Keep each step of the process in separate rooms or areas and minimize traffic between them.
 1. Reagent setup area: for micropipetting kit reagents only, except for the gelPCR control.
 2. Sampling area: for sampling the sheds, performing the lysis and PCR steps. Do not open tubes in this area after DNA has been amplified.
 3. DNA gel electrophoresis area: for running gels only.
- Dedicate a specific 2-20 µl micropipette and box of 20 µl filter tips for loading PCR samples into the gel. Never use this pipette and tips for preparing the PCR mix or for the DNA extraction step.
- Maintain a clean work area. Spray 5% bleach on work surfaces before and after every use.
- Prepare 5% bleach by 1 volume of household bleach to 19 volumes of distilled water.
- Change gloves between samples, or spray them with 5% bleach.
- Wear a clean lab coat when preparing the reagents.
- Discard materials such as tips, tubes, and gloves in a container that can be closed. Empty it often and clean it with 5% bleach.
- Keep all tubes closed except for the one that you are actively using.

Failure to follow good laboratory practices can result in contamination that will invalidate results. A contaminated laboratory is difficult to clean up.

CONTROLS

Negative control (highly recommended)

We strongly encourage you to run a negative control tube containing the DEB™ Extraction Buffer and PCR reagents but no DNA sample to check for possible contamination. We recommend running one negative control reaction with every PCR run. Presence of DNA bands in gel electrophoresis of the negative control is indicative of contamination and invalidates the results of all samples in the run.

Positive control (recommended if available)

We encourage you to run a positive control reaction for every PCR run. The ideal sample for the positive control is DNA extracted from a known heterozygous Lavender Albino. This will help you recognize the two possible expected bands and clearly determine the genotype of the unknown samples. Check the section "Expected results" for more information.

gelPCR Control (recommended for new users)

The gelPCR Control 1 reaction will generate a ~900 bp band. The presence of this band is indicative that the PCR master mix was prepared correctly and the PCR program was run as expected. We encourage you to run this reaction in parallel to your tests, especially when getting familiar with micropipetting technique and learning the PCR process.

TUBE TYPES

| Tube type | Picture | Description |
|------------------------------|---------|--|
| Screw-cap reagent tube | | Reagents for DNA extraction, PCR, and DNA gel electrophoresis. |
| 1.5 ml microcentrifuge tubes | | Used to prepare PCR mix. They are not included in the kit. Available at dx.minipcr.com |
| PCR tubes | | Used for the lysis and PCR steps. Included in the kit. |

Ball Python Lavender Albino DNA Test

MICROPIPETTING

Good micropipetting skills are essential to run the test successfully. Practice with water or colored liquids before using the reagents in this kit.

We recommend to dedicate









- one 100-1000 µl micropipette and one 20-200 µl micropipette to the “reagent setup area” for preparing the reagents (see section “STEP 1: SETUP”)
- one 1-10 µl micropipette to the “PCR area” for transferring the lysate and gelPCR™ Control 1 into the PCR mix (see section “STEP 3: PCR”)
- one 2-20 µl micropipette for the DNA gel electrophoresis area for loading gels only (see section “STEP 4: DNA GEL ELECTROPHORESIS AND VISUALIZATION”).



Micropipetting Videotutorial

Dedicating specific micropipettes and tip boxes to each area will reduce the contamination risk.

Always select the right micropipette and tip based on the volume that you need to transfer according to the table below.

| Volume range | Micropipette | Tips |
|--------------|--|---|
| 1-10 µl |  H10 |  10 µl micropipette filter tips 96 sterile tips, 0.5-10 µl volume |
| 2-20 µl |  H20 |  20 µl micropipette filter tips 96 sterile tips, 2-20 µl volume |
| 20-200 µl |  H200 |  200 µl micropipette filter tips 96 sterile tips, 20-200 µl volume |
| 100-1000 µl |  H1000 |  1000 µl micropipette filter tips 96 sterile tips, 100-1000 µl volume |

Ball Python Lavender Albino DNA Test

LIQUID HANDLING

Use a microcentrifuge to collect the liquid at the bottom of the tubes. Alternatively, use a strong and quick flick of the wrist to collect the liquid at the bottom of the tube.

To avoid contamination, make sure that all liquid is collected at the bottom of the tubes before opening them.

Follow these steps to use the microcentrifuge:

1. Ensure that the contents of the tubes are fully defrosted.
2. Place the tubes in the rotor, making sure they are balanced as shown in the pictures. The tubes should have approximately the same amount of liquid in them. If needed, prepare a tube with water to balance the rotor. Refer to the manufacturer's instructions for details.
3. Spin for 5 seconds at 10,000 RPM.

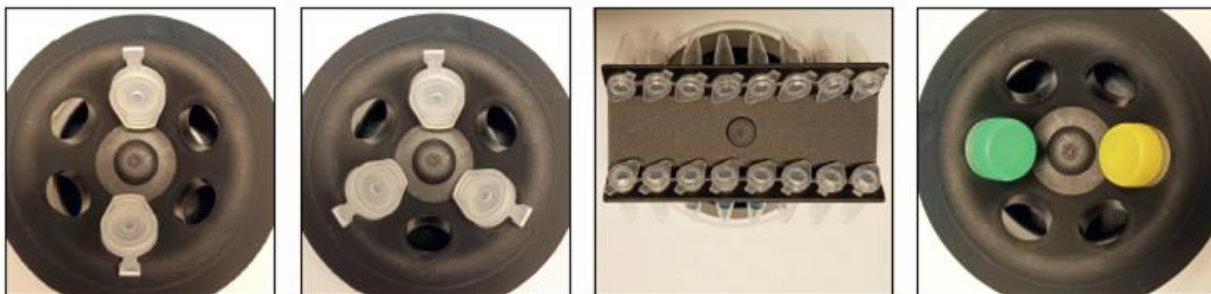

Examples of balanced microcentrifuges. Tubes match in size and contain the same volumes, making their weights comparable

PROGRAM THE miniPCR® OR OTHER THERMAL CYCLER

This is a one-time setup. The program will be saved in the software library and can be reused.



miniPCR® User's manual



Program the miniPCR®

Shed DNA extraction

1. Click or tap on the (+) symbol on the top right corner of the app.
2. Select "Heat Block".
3. Enter information:
 - a. Name: "Shed DNA extraction" or name of your choice
 - b. 95 °C
 - c. 10 min
4. Click or tap "Save".

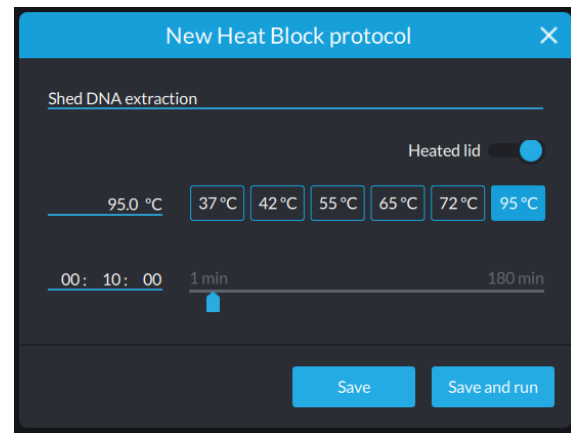

Ball Python PCR 1

1. Click or tap on the (+) symbol.
2. Select "PCR".
3. Enter information:
 - a. Name: "Ball Python PCR 1" or name of your choice
 - b. Initial denaturation 95 °C, 720 sec
 - c. Denaturation 95 °C, 5 sec
 - d. Annealing 57 °C, 30 sec
 - e. Extension 72 °C, 45 sec
 - f. Number of cycles 34
 - g. Final extension 72 °C, 45 sec
5. Click or tap "Save".

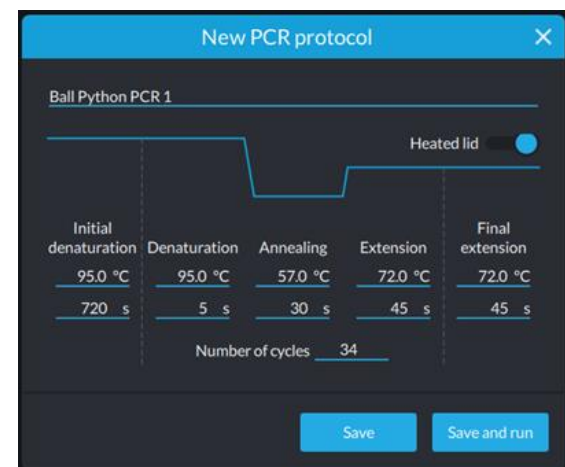

SHED COLLECTION

- You will not need an entire shed for a test, a small piece is sufficient (you will use 1 dorsal scale per test, we recommend collecting at least 1 inch of shed).
- Wear gloves when collecting and handling the shed.
- Collect the shed and gently remove any particles and dirt.
- Fully dry it at room temperature for 1-2 days until all moisture has evaporated. Moisture can lead to rotten sheds that cannot be analyzed with this test.
- Once the shed is dry, store it in a labeled zip lock bag. Dry sheds will be stable for several months in the freezer. To use, remove from the freezer and wait five minutes before collecting the sample.
- If collecting sheds from different animals at the same time, make sure you clean your gloves with 5% bleach between samples and keep them in separate bags to avoid contamination.

SCIENTIFIC BASIS OF THE ASSAY

This assay originates from the Ball Python Genetic Project, a course-based research program led by Dr. Hannah Seidel at Eastern Michigan University. Undergraduates identify the genes and mutations responsible for color morphs in ball pythons. Samples are donated by pet owners and breeders across the United States, and results are published in open-access scientific publications. These publications empower individuals to conduct genetic testing on their own animals.

Wild type



Photo: Chiron Graves

Lavender Albino

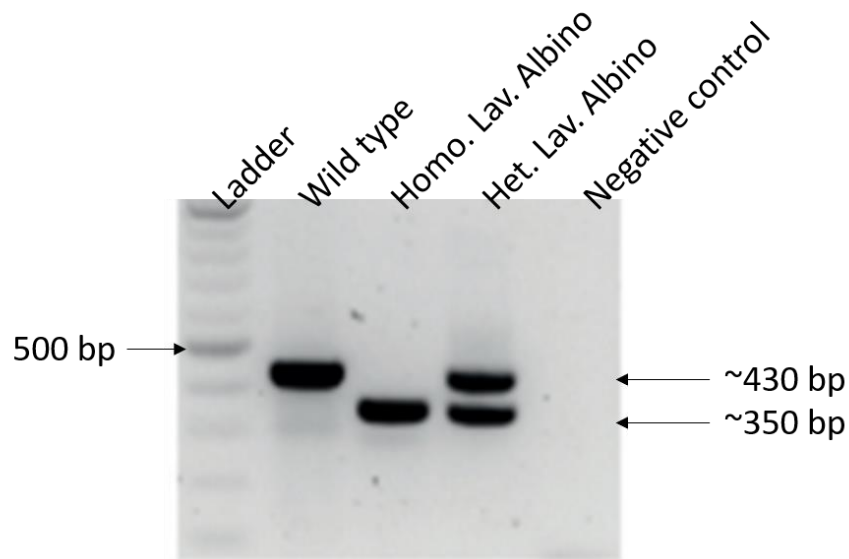
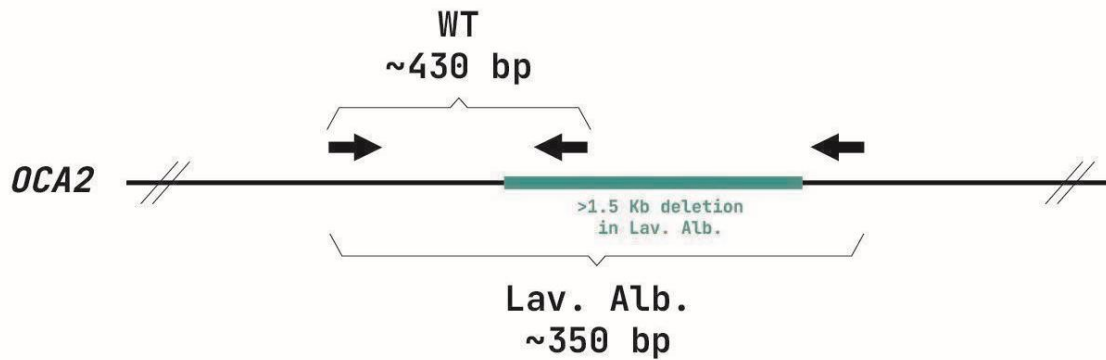

Photo: Ryan Young of
Molecular Reptile

The Lavender Albino color morph exhibits lavender skin patches instead of brown or black. This phenotype arises from reduced melanin levels, a pigment produced by skin cells. The color variation is attributed to a deletion within the *OCA2* gene. *OCA2* makes a protein that regulates cellular pH in melanin-producing areas. The deletion in Lavender Albino animals likely elevates pH, inhibiting melanin-producing enzymes. Consequently, less melanin is synthesized.

The *OCA2* gene is named after a human genetic condition known as Oculocutaneous Albinism Type 2, the most prevalent form of albinism caused by mutations in the human *OCA2* gene. Individuals with this condition have skin, hair, and eyes that are unusually pale. This phenotype is similar to the Lavender Albino color morph in ball pythons.

The deletion in Lavender Albino can be detected using PCR and DNA gel electrophoresis. The PCR test uses primers that produce products of different sizes, depending on genotype. DNA fragments from animals homozygous for the Lavender Albino allele will be ~350 bp long, while DNA from wild-type animals will be ~430 bp long. DNA amplified from heterozygotes will be ~350 and ~430 bp long.



We thank Dr. Hannah Seidel, Schmidt, Pamela S, and Charlie Williams for donating sheds necessary to optimize and validate this kit.

References

[Ball Python Genetics Project](#)

Brown AR, Comai K, Mannino D, McCullough H, Donekal Y, Meyers HC, et al. (2022) A community-science approach identifies genetic variants associated with three color morphs in ball pythons (*Python regius*). PLoS ONE 17(10): e0276376.

PROTOCOL

STEP 1. SETUP (10 MIN)

First, you will prepare the reagents needed for the lysis and PCR.

Note, “complete mix” is the combination of 5X HOT Multiplex PCR Master Mix, and 1.2X Lav. Albino Primers.

Prepare the DEB™ Extraction Buffer and the complete mix in an area isolated from where the sample collection and amplification are performed to prevent contamination with snake DNA.

1. Wear clean gloves.
2. Clean the surface of the reagent setup area with freshly prepared 5% bleach.
3. Prepare enough reagents to account for the number of shed samples that you are testing, the positive and negative controls, and the optional gelPCR control.

Example with gelPCR control

| Shed samples | Negative control | Positive control | gelPCR control | Total tests |
|--------------|------------------|------------------|----------------|-------------|
| 6 | 1 | 1 | 1 | 9 |

Example without gelPCR control

| Shed samples | Negative control | Positive control | Total tests |
|--------------|------------------|------------------|-------------|
| 6 | 1 | 1 | 8 |

4. Thaw the DEB™ DNA Extraction Buffer, the 5X HOT Multiplex PCR Master Mix, and the 1.2X Lav. Albino Primers at room temperature. Ensure that the DEB™ DNA Extraction Buffer tube has no precipitates (solids) at the bottom. If present, shake well until the solution is homogeneous. Verify that all liquid is at the bottom of the tube before proceeding.
5. Label a strip of PCR tubes with your sample’s IDs. Mark the strip with a “DE” (as “DNA Extraction”). The tubes for the positive and negative controls should be as far apart from each other as possible (e.g., negative control in the first tube, positive control in the last tube). You will need one PCR tube per test.

6. Open the tubes and add **50 µl of DEB™ Extraction Buffer** to each tube using a 20-200 µl micropipette and the appropriate filter tip.
7. Close all the tubes. Tubes might be hard to close!



Example of a 20-200 µl micropipette set to 50 µl

8. Label a second strip of PCR tubes. Mark the strip with a “P” (as “PCR”). The tubes for the negative and the positive controls should be as far apart from each other as possible. You will need one PCR tube per test.
9. Prepare enough complete mix as indicated in the following table. Combine the volumes of 5X HOT Multiplex PCR Master Mix, and the 1.2X Lav. Albino Primers in a 1.5 ml microcentrifuge tube.
 - “Number of total tests” is the sum of unknown shed samples, the negative control, the shed used as positive control, and the gelPCR control.
 - These calculations account for the loss of volume during pipetting. You may have a small amount of liquid left in the tube.
 - For other numbers of tests, multiply the volumes required for 1 sample by the total number of tests.

| | Number of total tests | |
|--------------------------------------|-----------------------|------------|
| | 1 | 8 |
| 5X HOT Multiplex PCR Master Mix (µl) | 5.5 | 44 |
| 1.2X Lav. Albino Primers (µl) | 22 | 176 |
| Total volume (µl) | 27.5 | 220 |

10. Mix well but slowly by pipetting up and down at least six times, being careful not to introduce bubbles.
11. Add **23 µl of the complete mix** to each PCR tube (use the strip designated for PCR labeled as “P”) using a 20-200 µl micropipette and the appropriate filter tip.

Remember to push the plunger only till the first stop when aspirating liquid.

12. Close all tubes. Tap them lightly on the benchtop or briefly spin them in a microcentrifuge to collect all the liquid at the bottom of the tubes.

Remember to bring the 5X HOT Multiplex PCR Master Mix and the 1.2X Lav. Albino Primers back into the freezer. Once thawed, the DEB™ Extraction Buffer can be stored at room temperature.

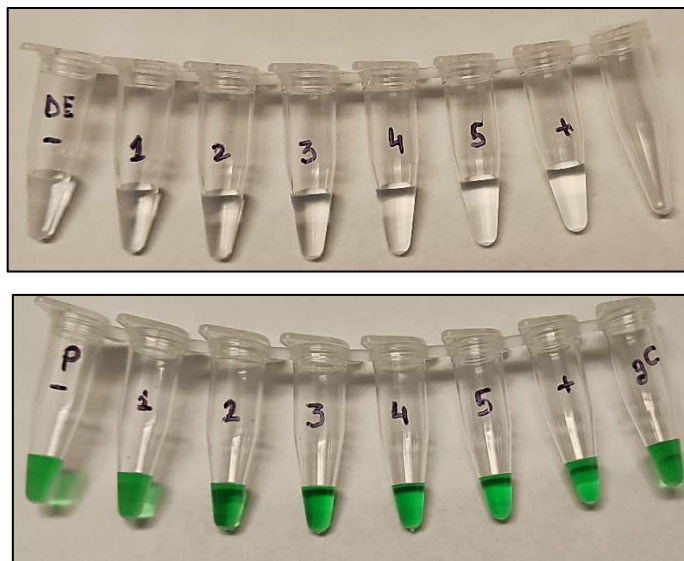

Example of tubes containing the DEB™ Extraction Buffer (top, transparent liquid) and the complete mix (bottom, green liquid).

The negative control is indicated with “-”, the positive with “+”, and the gelPCR control with “gC”.

STEP 2. LYSIS (20 MIN)

10 minutes hands-on followed by 10 minutes incubation.

You will now extract DNA from the sheds by adding scales to the tubes containing the DEB™ Extraction Buffer. Open only one tube at a time to avoid contamination.

1. Wear clean gloves and clean the surface of the sample collection area with freshly prepared 5% bleach.
2. Tap the tubes labeled as DE (transparent liquid). lightly on the benchtop or briefly spin them in a microcentrifuge to collect the liquid at the bottom.
3. Always keep the first tube (negative control) closed.
4. Place a piece of shed on a clean support (e.g., parchment paper) and cut a piece ~4 mm of diameter from the dorsal shed (about 1-4 scales), using a disposable tweezer or scalpel.

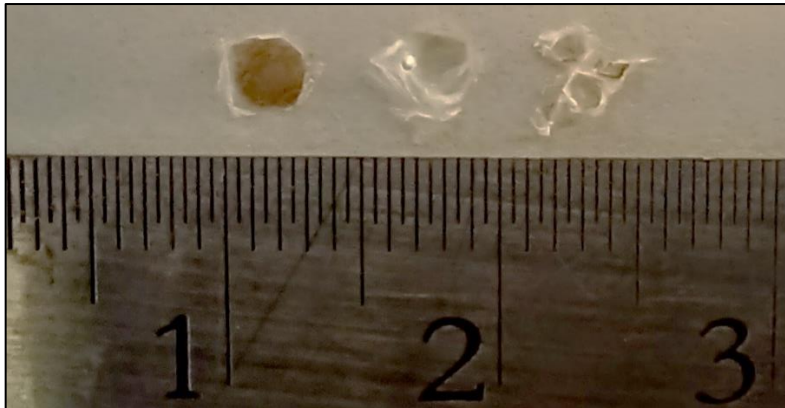

Example of samples of dorsal scales. Ruler in cm.

5. Open the corresponding tube and add the shed.
6. Discard the shed collection tool into the waste container. If the scalpel or the blade was protected with a cover, discard it in a sharps container without replacing the cover to avoid injuries.
7. **Make sure that the piece of shed is completely submerged in the liquid.** You can use a clean toothpick to push the scale into the liquid.
8. If used, discard the toothpick.
9. Close the tube.
10. Put the shed back into its bag.
11. Dispose the parchment paper.
12. Clean the surface with 5% bleach.
13. Change gloves or clean them with 5% bleach.
14. Process the next samples following steps 4 to 14. If available, process the positive control last.
15. When all the samples are ready, make sure that all the caps are safely closed.

Ball Python Lavender Albino DNA Test

16. Gently tap the tubes to collect the liquid at the bottom or briefly spin the strip in the microcentrifuge.
17. Load the samples into the miniPCR® or another thermal cycler. Close the lid.
18. Run the “Shed DNA extraction” program.

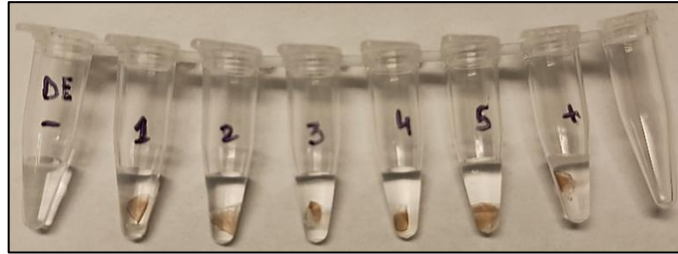

Example of tubes containing the shed samples for extracting DNA.

Ball Python Lavender Albino DNA Test

STEP 3. PCR (95 MIN)

5 minutes hands-on followed by 90 minutes PCR run.

In this step, you will add the extracted DNA (transparent liquid) to the complete mix (green liquid) and run the PCR. Open only one tube at a time to avoid possible contamination.

1. Wear clean gloves.
2. Position the strip containing the shed DNA (labeled “DE”, transparent liquid) on one miniRack and the strip containing the PCR mix (labeled “P”, green liquid) on another miniRack.
3. Open the first tube on both strips (negative control).
4. Using the dedicated 1-10 μ l micropipette and the appropriate filter tip, transfer 2 μ l from the lysis tube to the PCR mix tube
5. Discard the tip.
6. Close both tubes.



Example of a 1-10 μ l micropipette

7. Repeat steps 2-5 for all samples, making sure that you process one sample at the time.
8. Make sure that all tubes are closed.
9. If using gelPCR Control 1:
 - a. Make sure that gelPCR Control 1 has thawed.
 - b. Tap the tube gently on the bench or briefly spin it in a microcentrifuge to ensure that the liquid is at the bottom.
 - c. Open the screw-cap gelPCR Control 1 and also open the relative PCR tube.

Ball Python Lavender Albino DNA Test

- d. Using a 1-10 μ l micropipette or a 2-20 μ l micropipette with a filter tip, transfer 2 μ l of gelPCR Control into the assigned tube.
- e. Discard the tip.
10. Close the gelPCR Control 1 and PCR tubes.
11. Flick the “P” strip (green liquid) and tap down, to make sure all the liquid is at the bottom. Alternatively, briefly spin in the microcentrifuge.
12. Load the samples into the miniPCR® or another thermal cycler.
13. Run the “Ball Python PCR 1” program.

Remember to bring the gelPCR Control 1 back to the freezer.

Note:

Once the PCR program has finished, samples can stay at room temperature overnight before running the DNA gel electrophoresis.

STEP 4. DNA GEL ELECTROPHORESIS AND VISUALIZATION (45 MIN)

In this step you will prepare the setup for the DNA gel electrophoresis. You can cast the agarose gel and prepare the 1X TBE buffer while the “Ball Python PCR 1” is running.

1. Prepare the gel casting platform. Make sure that the comb is inserted.
2. If using SeeGreen™ All-in-One Agarose Tabs™ and blueGel™, follow the instructions for preparing a 2% gel.
 - a. For one blue gel, soak one tab in 20 ml of water and swirl for about 3 min, till the tab is fully dissolved.
 - b. Then, heat the solution until it is clear and all particles are dissolved (typically 30 - 60 seconds in a high-power microwave).
 - c. Pour the liquid into the casting platform.
 - d. Allow gel to solidify completely.
 - i. Gels will typically be ready in about 10 minutes.
 - ii. Gel is ready when cool and firm to the touch.

Alternatively, prepare a 2% Agarose gel in 1X TBE buffer with the appropriate amount of DNA staining dye.



How to pour a gel and prepare 1X TBE

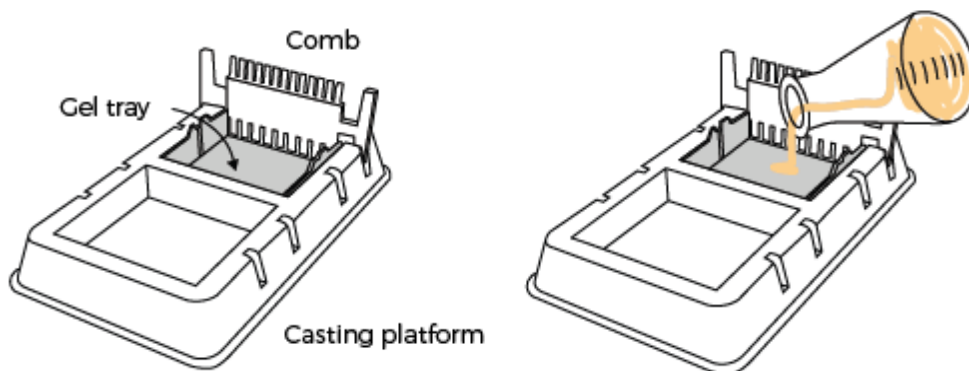

3. Once the gel is solid and the “Ball Python PCR 1” program is concluded, it is time to run the DNA gel electrophoresis.
4. Remove the comb by pulling firmly upwards and place the gel tray containing your gel in the buffer chamber. If using a blueGel™:
 - a. Ensure that the clear buffer chamber is inside the blueGel™ electrophoresis system.
 - b. The wells of the gel should be on the same side as the negative electrode, away from the power button.
5. Prepare the 1X TBE buffer by following the instructions on the container.
6. Add 1X TBE electrophoresis buffer to the chamber. If using a blueGel™, use 30 ml of 1X TBE buffer.
 - a. The buffer should just cover the gel and fill the wells.

- b. Ensure that there are no air bubbles in the wells (shake the gel gently if bubbles need to be dislodged).

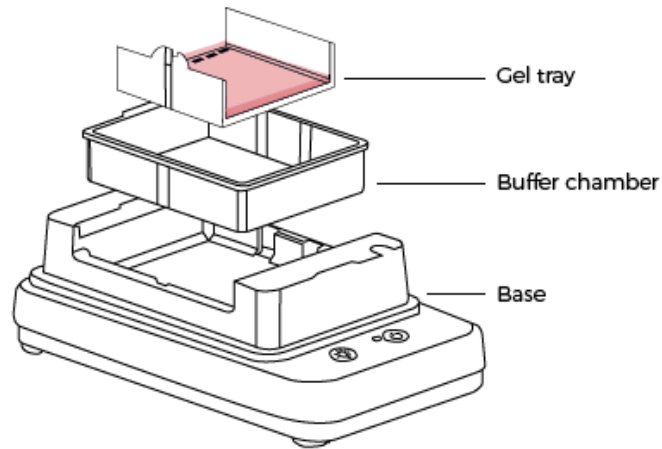

Once the “Ball Python PCR 1” program is completed:

- Tap down or briefly centrifuge the tubes to make sure that the liquid (including possible condensation drops on the top of the tube) collects at the bottom before opening the tubes.
- Open the tubes only in the dedicated post-PCR area and use the dedicated micropipette and filter tips.
- Never open the tubes in the area where you prepare the PCR mix or collect shed DNA samples.
- Never use the micropipettes and the filter tips that you use for the pre-PCR steps for handling the post-PCR samples.

These practices will reduce the risk of contamination.

7. Using the dedicated 2-20 μ l micropipette and 20 μ l filter tips, load 10 μ l of 100 bp DNA ladder, Load Ready™ in the first lane of the gel.

Once thawed, the DNA ladder can be stored at room temperature.

Ball Python Lavender Albino DNA Test

8. Load 10 µl of each PCR test in each well. Keep track of the order and change tips between samples.
9. Run the DNA gel electrophoresis.

Specifically, if using a blueGel™:

- a. Place the orange cover on the blueGel™ electrophoresis system.
- b. To prevent fogging, make sure that ClearView™ spray has been evenly applied to the inside of the orange cover.
- c. Match the positive and negative electrode signs on the orange lid with the corresponding positive and negative signs on the blue base.
- d. The orange lid should sit flush with the blue base using little force.
- e. Press the “Run” button. Check that the green light beside the power button remains illuminated.

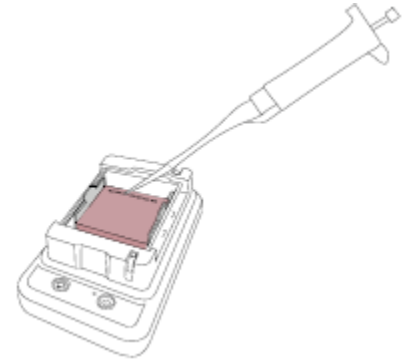

blueGel™ User's guide

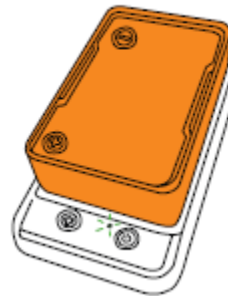

10. Conduct electrophoresis for 15-30 minutes. Check gel and take a picture every 15 minutes to monitor sample migration (follow instructions on step 11 and 12).

Note

- Longer electrophoresis times will result in better size resolution.
- However, if run too long, small DNA fragments can run off the end of the gel or lose fluorescence.
- If using GELATO™ electrophoresis and visualization system, run DNA gel electrophoresis at 135 V and take a picture at 10 minutes and at 20 minutes. Please, refer to GELATO™ User's guide to operate the instrument.



GELATO™ User's guide

11. Visualize the result using a transilluminator. If using a blueGel™
 - a. Press the “light bulb” button to turn on the blueGel™ transilluminator.
 - b. For best viewing, dim lights or use the Fold-a-View™ photo documentation hood with a smartphone camera.
 - c. If the image appears hazy, wipe off the inside of the orange cover and reapply ClearView™ spray.
 - d. Ensure that there is sufficient DNA band resolution in the 300-500 bp range of the 100bp DNA ladder, Load Ready™. Run the gel longer if needed to increase resolution.
12. Take a picture and document your result.
 - a. Place Fold-a-View™ photo documentation hood on the blueGel™ electrophoresis system to take a picture with a smartphone or other digital camera.
 - b. Compare the bands from the DNA samples to the ladder to obtain size estimates and interpret the result (check “Expected results” section).

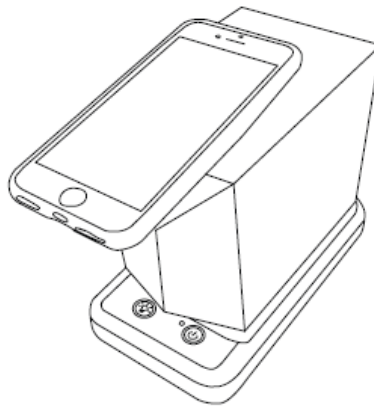

Ball Python Lavender Albino DNA Test

EXPECTED RESULTS

- The negative control should show no bands. Bands appearing in the negative control signify contamination, invalidating the results of the experiment.
- Homozygous wild-type snakes will yield a single ~430 bp band.
- Homozygous Lavender Albino snakes will produce a single ~350 bp band.
- Heterozygous Lavender Albino snakes will produce two bands (~350 bp and ~430 bp, respectively).
- gelPCR Control 1 will yield a band at ~900 bp

EXAMPLE RESULTS

Lane 1: Ladder

Lane 2: Negative control (no DNA)

Lanes 3 and 4: known homozygous wild type (WT)

Lanes 5 and 6: known homozygous Lavender Albino

Lanes 7 and 8: known heterozygous Lavender Albino

Lane 9: gelPCR Control 1

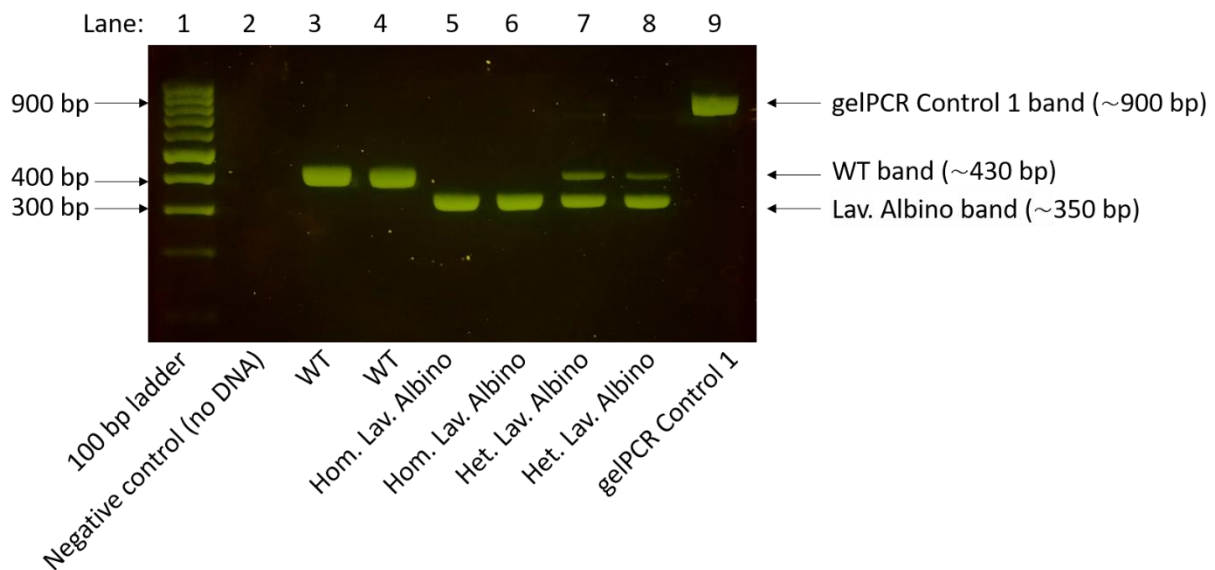

Questions? Email dx@minipcr.com or call +1-781-990-8727 for technical support.